



The Future of Analog IC Technology™

# MP1410

## 2A, 15V, 380KHz Step-Down Converter

### DESCRIPTION

The MP1410 is a monolithic step-down switch mode regulator with a built in internal power MOSFET. It achieves 2A continuous output current over a wide input supply range with excellent load and line regulation.

Current mode operation provides fast transient response and eases loop stabilization.

Fault condition protection includes cycle-by-cycle current limiting and thermal shutdown. In shutdown mode the regulator draws 25µA of supply current.

The MP1410 requires a minimum number of readily available standard external components.

### EVALUATION BOARD REFERENCE

Board Number	Dimensions
EV0012	1.5"X x 1.4"Y x 0.7"Z

### FEATURES

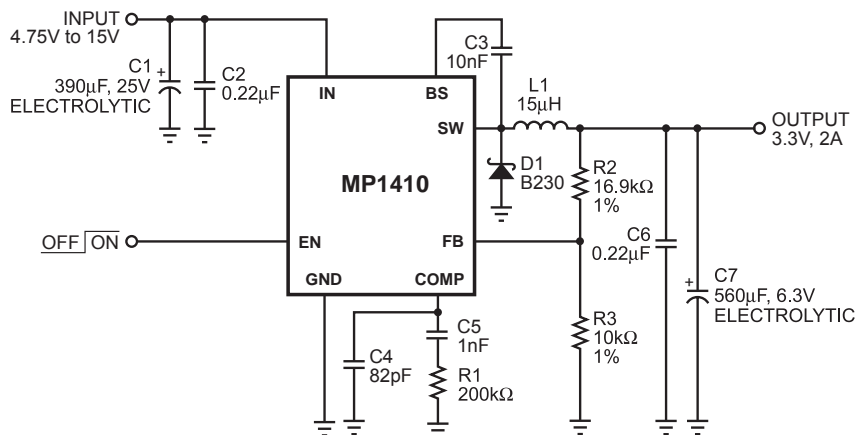
- 2A Output Current
- 0.22Ω Internal Power MOSFET Switch
- Stable with Low ESR Output Ceramic Capacitors
- Up to 95% Efficiency
- 25µA Shutdown Mode
- Fixed 380KHz Frequency
- Thermal Shutdown
- Cycle-by-Cycle Over Current Protection
- Wide 4.75V to 15V Operating Input Range
- Output Adjustable from 1.22V to 13V
- Programmable Under Voltage Lockout
- Available in 8-Pin SOIC and PDIP Packages

### APPLICATIONS

- PC Monitors
- Distributed Power Systems
- Battery Charger
- Pre-Regulator for Linear Regulators

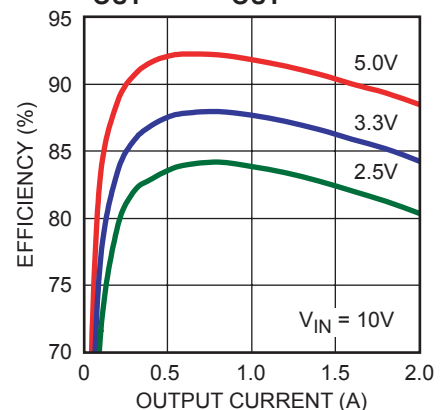
"MPS" and "The Future of Analog IC Technology" are Trademarks of Monolithic Power Systems, Inc.

### TYPICAL APPLICATION



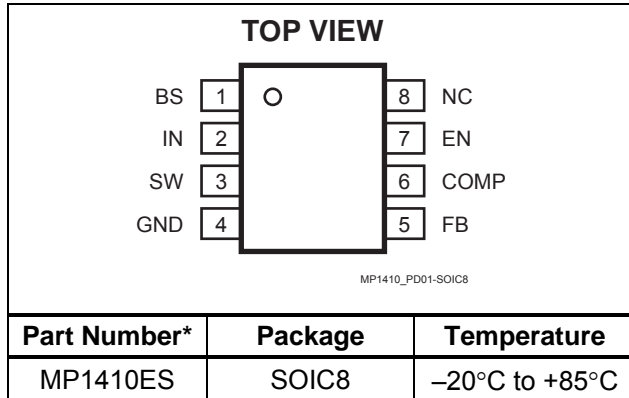
MP1410\_TAC\_S01

Efficiency vs  
I<sub>OUT</sub> and V<sub>OUT</sub>



MP1410\_TAC\_EC01

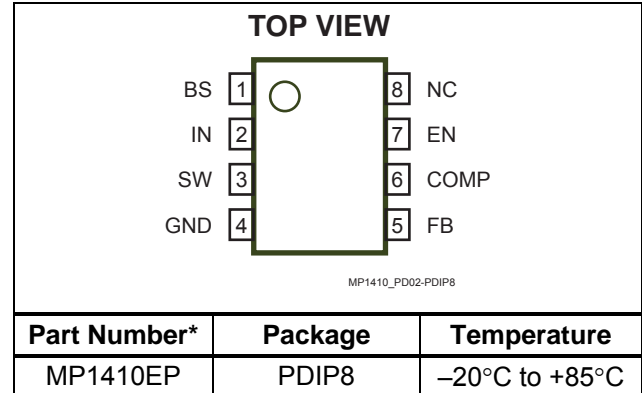
## PACKAGE REFERENCE



\* For Tape & Reel, add suffix -Z (eg. MP1410ES-Z)  
For Lead Free, add suffix -LF (eg. MP1410ES-LF-Z)

**ABSOLUTE MAXIMUM RATINGS** <sup>(1)</sup>

Input Voltage ( $V_{IN}$ )	-0.3V to +16V
Switch Voltage ( $V_{SW}$ )	-1V to $V_{IN} + 1V$
Bootstrap Voltage ( $V_{BS}$ )	$V_{SW} - 0.3V$ to $V_{SW} + 6V$
All Other Pins	-0.3 to +6V
Junction Temperature	150°C
Lead Temperature	260°C
Storage Temperature	-65°C to +150°C



\* For Tape & Reel, add suffix -Z (eg. MP1410EP-Z)  
For Lead Free, add suffix -LF (eg. MP1410EP-LF-Z)

**Recommended Operating Conditions** <sup>(2)</sup>

Input Voltage ( $V_{IN}$ )	4.75V to 15V
Operating Temperature	-20°C to +85°C

**Thermal Resistance** <sup>(3)</sup>

	$\theta_{JA}$	$\theta_{JC}$	
SOIC8	90	42	°C/W
PDIP8	95	50	°C/W

**Notes:**

- Exceeding these ratings may damage the device.
- The device is not guaranteed to function outside of its operating conditions.
- Measured on approximately 1" square of 1 oz copper.

## ELECTRICAL CHARACTERISTICS

$V_{IN} = 12V$ ,  $V_{EN} = 5V$ ,  $T_A = +25^\circ C$ , unless otherwise noted.

Parameter	Symbol	Condition	Min	Typ	Max	Units
Feedback Voltage		$4.75V \leq V_{IN} \leq 15V$	1.184	1.222	1.258	V
Upper Switch On Resistance				0.22		$\Omega$
Lower Switch On Resistance				10		$\Omega$
Upper Switch Leakage		$V_{EN} = 0V$ , $V_{SW} = 0V$			10	$\mu A$
Current Limit			2.4	3.1		A
Oscillator Frequency			320	380	440	KHz
Short Circuit Frequency		$V_{FB} = 0V$		42		KHz
Maximum Duty Cycle		$V_{FB} = 1.0V$		90		%
Minimum Duty Cycle		$V_{FB} = 1.5V$			0	%
Enable Threshold			0.7	1.1	1.4	V
Under Voltage Lockout Threshold Rising			2.0	2.5	3.0	V
Under Voltage Lockout Threshold Hysteresis				200		mV
Shutdown Supply Current		$V_{EN} = 0V$		25	50	$\mu A$
Operating Supply Current		$V_{FB} = 1.4V$		1.0	1.5	mA
Thermal Shutdown				160		°C

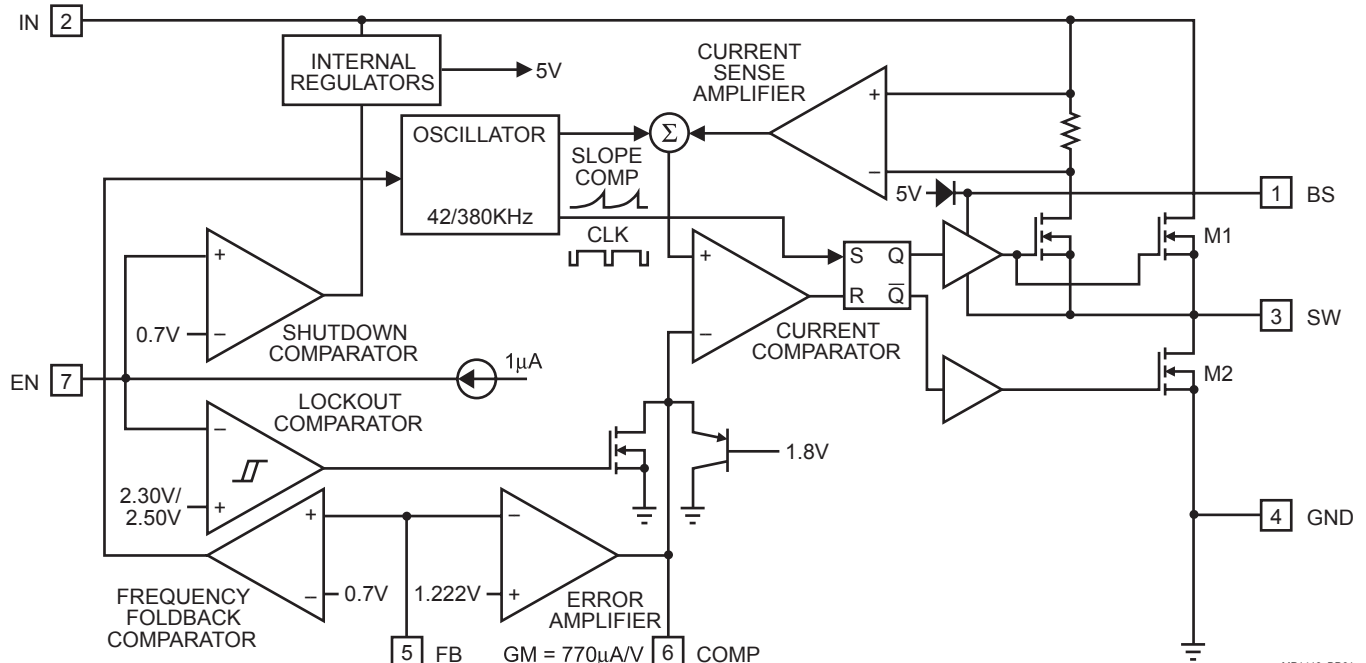
## PIN FUNCTIONS

Pin #	Name	Description
1	BS	High-Side Gate Drive Boost Input. BS supplies the drive for the high-side N-Channel MOSFET switch. Connect a 10nF or greater capacitor from SW to BS to power the switch.
2	IN	Power Input. IN supplies the power to the IC, as well as the step-down converter switch. Drive IN with a 4.75V to 15V power source. Bypass IN to GND with a suitably large capacitor to eliminate noise on the input to the IC. <b>See Input Capacitor.</b>
3	SW	Power Switching Output. SW is the switching node that supplies power to the output. Connect the output LC filter from SW to the output load. Note that a capacitor is required from SW to BS to power the high-side switch.
4	GND	Ground.
5	FB	Feedback Input. FB senses the output voltage to regulate that voltage. Drive FB with a resistive voltage divider from the output voltage. The feedback threshold is 1.222V. <b>See Setting the Output Voltage.</b>
6	COMP	Compensation Node. COMP is used to compensate the regulation control loop. Connect a series RC network from COMP to GND to compensate the regulation control loop. <b>See Compensation.</b>
7	EN	Enable Input. EN is a digital input that turns the regulator on or off. Drive EN high to turn on the regulator, low to turn it off. For automatic startup, leave EN unconnected.
8	NC	No Connect.

## OPERATION

The MP1410 is a current-mode step-down switch-mode regulator. It regulates input voltages from 4.75V to 15V down to an output voltage as low as 1.222V and is able to supply up to 2A of load current. The MP1410 uses current-mode control to regulate the output voltage. The output voltage is measured at FB through a resistive voltage divider and amplified through the internal error amplifier. The output current of the transconductance error amplifier is presented at COMP where a network compensates the regulation control system. The voltage at COMP is compared to the switch current measured internally to control the output voltage.

The converter uses an internal N-Channel MOSFET switch to step down the input voltage to the regulated output voltage. Since the MOSFET requires a gate voltage greater than the input voltage, a boost capacitor connected between SW and BS drives the gate. The capacitor is internally charged while the switch is off. An internal 10Ω switch from SW to GND is used to ensure that SW is pulled to GND when the switch is off to fully charge the BS capacitor.



**Figure 1—Functional Block Diagram**

MP1410\_BD01

## APPLICATION INFORMATION

### COMPONENT SELECTION

#### Setting the Output Voltage

The output voltage is set using a resistive voltage divider from the output voltage to FB (see Typical Application circuit on page 1). The voltage divider divides the output voltage down by the ratio:

$$V_{FB} = V_{OUT} \times \frac{R3}{(R2 + R3)}$$

Where  $V_{FB}$  is the feedback voltage and  $V_{OUT}$  is the output voltage.

Thus the output voltage is:

$$V_{OUT} = 1.222 \times \frac{(R2 + R3)}{R3}$$

$R3$  can be as high as 100k $\Omega$ , but a typical value is 10k $\Omega$ . Using that value,  $R2$  is determined by:

$$R2 \cong 8.18 \times (V_{OUT} - 1.222)$$

For example, for a 3.3V output voltage,  $R3$  is 10k $\Omega$ , and  $R2$  is 16.9k $\Omega$ .

#### Inductor

The inductor is required to supply constant current to the output load while being driven by the switched input voltage. A larger value inductor results in less ripple current that results in lower output ripple voltage. However, the larger value inductor has a larger physical size, higher series resistance and/or lower saturation current. Choose an inductor that does not saturate under the worst-case load conditions. A good rule for determining the inductance is to allow the peak-to-peak ripple current in the inductor to be approximately 30% of the maximum load current. Also, make sure that the peak inductor current (the load current plus half the peak-to-peak inductor ripple current) is below the 2.4A minimum current limit.

The inductance value can be calculated by the equation:

$$L = V_{OUT} \times \frac{(V_{IN} - V_{OUT})}{(V_{IN} \times f \times \Delta I)}$$

Where  $V_{IN}$  is the input voltage,  $f$  is the switching frequency, and  $\Delta I$  is the peak-to-peak inductor ripple current.

Table 1 lists a number of suitable inductors from various manufacturers.

**Table 1—Inductor Selection Guide**

Vendor/ Model	Core Type	Core Material	Package Dimensions (mm)		
			W	L	H
<b>Sumida</b>					
CR75	Open	Ferrite	7.0	7.8	5.5
CDH74	Open	Ferrite	7.3	8.0	5.2
CDRH5D28	Shielded	Ferrite	5.5	5.7	5.5
CDRH5D28	Shielded	Ferrite	5.5	5.7	5.5
CDRH6D28	Shielded	Ferrite	6.7	6.7	3.0
CDRH104R	Shielded	Ferrite	10.1	10.0	3.0
<b>Toko</b>					
D53LC Type A	Shielded	Ferrite	5.0	5.0	3.0
D75C	Shielded	Ferrite	7.6	7.6	5.1
D104C	Shielded	Ferrite	10.0	10.0	4.3
D10FL	Open	Ferrite	9.7	1.5	4.0
<b>Coilcraft</b>					
DO3308	Open	Ferrite	9.4	13.0	3.0
DO3316	Open	Ferrite	9.4	13.0	5.1

#### Input Capacitor

The input current to the step-down converter is discontinuous, and therefore an input capacitor  $C1$  is required to supply the AC current to the step-down converter while maintaining the DC input voltage. A low ESR capacitor is required to keep the noise at the IC to a minimum. Ceramic capacitors are preferred, but tantalum or low-ESR electrolytic capacitors may also suffice.

The input capacitor value should be greater than 10 $\mu$ F. The capacitor can be electrolytic, tantalum or ceramic. However, since it absorbs the input switching current it requires an adequate ripple current rating. Its RMS current rating should be greater than approximately 1/2 of the DC load current.

For insuring stable operation, C2 should be placed as close to the IC as possible. Alternately a smaller high quality ceramic 0.1µF capacitor may be placed closer to the IC and a larger capacitor placed further away. If using this technique, it is recommended that the larger capacitor be a tantalum or electrolytic type. All ceramic capacitors should be placed close to the MP1410.

### Output Capacitor

The output capacitor is required to maintain the DC output voltage. Low ESR capacitors are preferred to keep the output voltage ripple low. The characteristics of the output capacitor also affect the stability of the regulation control system. Ceramic, tantalum or low ESR electrolytic capacitors are recommended. In the case of ceramic capacitors, the impedance at the switching frequency is dominated by the capacitance and so the output voltage ripple is mostly independent of the ESR. The output voltage ripple is estimated to be:

$$V_{\text{RIPPLE}} \cong 1.4 \times V_{\text{IN}} \times \left( \frac{f_{\text{LC}}}{f} \right)^2$$

In the case of tantalum or low-ESR electrolytic capacitors, the ESR dominates the impedance at the switching frequency, and so the output ripple is calculated as:

$$V_{\text{RIPPLE}} \cong \Delta I \times R_{\text{ESR}}$$

### Output Rectifier Diode

The output rectifier diode supplies the current to the inductor when the high-side switch is off. To reduce losses due to the diode forward voltage and recovery times, use a Schottky rectifier.

Table 2 provides the Schottky rectifier part numbers based on the maximum input voltage and current rating.

**Table 2—Schottky Rectifier Selection Guide**

V <sub>IN</sub> (Max)	2A Load Current	
	Part Number	Vendor
15V	30BQ015	4
20V	B220	1
	SK23	6
	SR32	6

Table 3 lists some rectifier manufacturers.

**Table 3—Schottky Diode Manufacturers**

Vendor	Web Site
Diodes, Inc.	www.diodes.com
Fairchild Semiconductor	www.fairchildsemi.com
General Semiconductor	www.gensemi.com
International Rectifier	www.irf.com
On Semiconductor	www.onsemi.com
Pan Jit International	www.panjit.com.tw

Choose a rectifier the maximum reverse voltage rating of which is greater than the maximum input voltage, and has a current rating greater than the maximum load current.

### Compensation

The system stability is controlled through the COMP pin. COMP is the output of the internal transconductance error amplifier. A series capacitor-resistor combination sets a pole-zero combination to control the characteristics of the control system.

The DC loop gain is:

$$A_{\text{VDC}} = \frac{V_{\text{FB}}}{V_{\text{OUT}}} \times A_{\text{VEA}} \times G_{\text{CS}} \times R_{\text{LOAD}}$$

Where  $A_{\text{VEA}}$  is the transconductance error amplifier voltage gain (400V/V),  $G_{\text{CS}}$  is the current sense gain (roughly the output current divided by the voltage at COMP) equal to 1.95 A/V and  $R_{\text{LOAD}}$  is the load resistance ( $V_{\text{OUT}} / I_{\text{OUT}}$  where  $I_{\text{OUT}}$  is the output load current)

The system has two poles of importance, one is due to the compensation capacitor (C5), and the other is due to the output capacitor (C7). These are:

$$f_{\text{P1}} = \frac{G_{\text{EA}}}{2\pi \times A_{\text{VEA}} \times C5}$$

Where P1 is the first pole and  $G_{\text{EA}}$  is the error amplifier transconductance (770µA/V). The other pole is:

$$f_{\text{P2}} = \frac{1}{2\pi \times R_{\text{LOAD}} \times C7}$$

The system has one zero of importance, due to the compensation capacitor (C5) and the compensation resistor (R1). This is:

$$f_{Z1} = \frac{1}{2\pi \times R1 \times C5}$$

If a large value capacitor (C7) with relatively high equivalent-series-resistance (ESR) is used, the zero due to the capacitance and ESR of the output capacitor can be compensated by a third pole set by R1 and C4:

$$f_{P3} = \frac{1}{2\pi \times R1 \times C4}$$

The system crossover frequency (the frequency where the loop gain drops to 1 or 0dB) is important. A good rule of thumb is to set the crossover frequency to approximately one tenth of the switching frequency. In this case, the switching frequency is 380KHz. Therefore, use a crossover frequency ( $f_c$ ) of 40KHz. Lower crossover frequencies result in slower response and worse transient load recovery. Higher crossover frequencies can result in instability.

### Choosing the Compensation Components

The values of the compensation components given in Table 4 yield a stable control loop for the output voltage and capacitor given.

**Table 4—Compensation Values for Typical Output Voltage/Capacitor Combinations**

V <sub>OUT</sub>	C7	R1	C5	C4
2.5V	22µF Ceramic	7.5kΩ	2.2nF	None
3.3V	22µF Ceramic	10kΩ	2nF	None
5V	22µF Ceramic	15kΩ	1.2nF	None
12V	22µF Ceramic	33kΩ	1nF	None
2.5V	560µF/6.3V (30mΩ ESR)	150kΩ	1nF	100pF
3.3V	560µF/6.3V (30mΩ ESR)	200kΩ	1nF	82pF
5V	470µF/10V (30mΩ ESR)	250kΩ	1nF	56pF
12V	220µF/25V (30mΩ ESR)	250kΩ	1nF	27pF

To optimize the compensation components for conditions not listed in Table 4, use the following procedure:

Choose the compensation resistor to set the desired crossover frequency. Determine the value by the following equation:

$$R1 = 2\pi \times C7 \times V_{OUT} \times \frac{f_c}{(G_{EA} \times G_{CS} \times V_{FB})}$$

Putting in the known constants and setting the crossover frequency to the desired 40KHz:

$$R1 \approx 1.37 \times 10^8 \times C7 \times V_{OUT}$$

Choose the compensation capacitor to set the zero below one fourth of the crossover frequency.

Determine the value by the following equation:

$$C5 > \frac{0.22 \times C7 \times V_{OUT}}{R1}$$

Determine if the second compensation capacitor, C4 is required. It is required if the ESR zero of the output capacitor occurs at less than four times the crossover frequency.

$$8\pi \times C7 \times R_{ESR} \times f_c \geq 1$$

or:

$$\frac{7.34 \times 10^{-5} \times R1 \times R_{ESR}}{V_{OUT}} \geq 1$$

Where  $R_{ESR}$  is the equivalent series resistance of the output capacitor. If this is the case, add the second compensation capacitor. Determine the value by the equation:

$$C4 = \frac{C7 \times R_{ESR(MAX)}}{R1}$$

Where  $R_{ESR(MAX)}$  is the maximum ESR of the output capacitor.

**For Example:**

$$V_{OUT} = 3.3V$$

$$C7 = 22\mu F \text{ Ceramic (ESR} = 10m\Omega)$$

$$R1 \approx (1.37 \times 10^8) \times (22 \times 10^{-6}) \times 3.3 = 9.9k\Omega$$

Use the nearest standard value of 10kΩ.

$$C5 > \frac{(0.22 \times (22 \times 10^{-6}) \times 3.3)}{10 \times 10^3} = 1.6nF$$

Use a standard value of 2nF.

$$2\pi \times C7 \times R_{ESR} \times f_C = 0.014$$

This value is less than 1, therefore no second compensation capacitor is required.

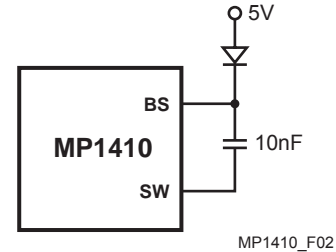
**Negative Output Voltage**

The MP1410 can be configured as a buck-boost converter to generate negative output voltage.

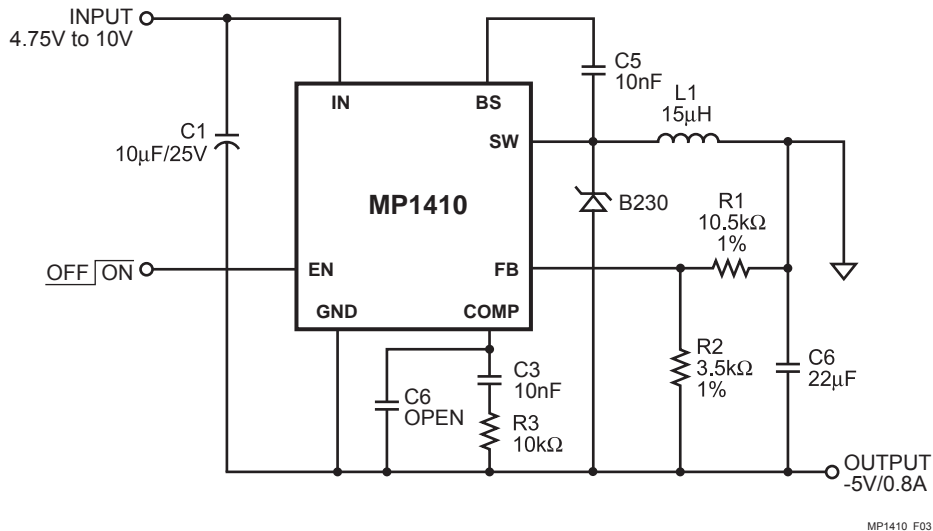
Because the GND pin of the IC is now connected to negative output voltage, the maximum allowable input voltage is the IC input voltage rating (15V) minus the negative output voltage value. A typical application circuit is shown in Figure 3.

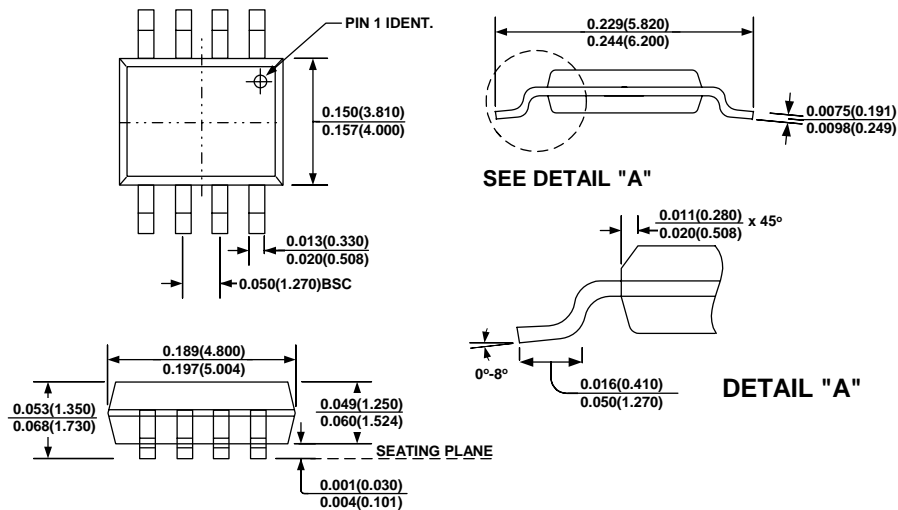
**External Bootstrap Diode**

It is recommended that an external bootstrap diode be added when the system has a 5V fixed input or the power supply generates a 5V output. This helps improve the efficiency of the regulator. The bootstrap diode can be a low cost one such as IN4148 or BAT54.

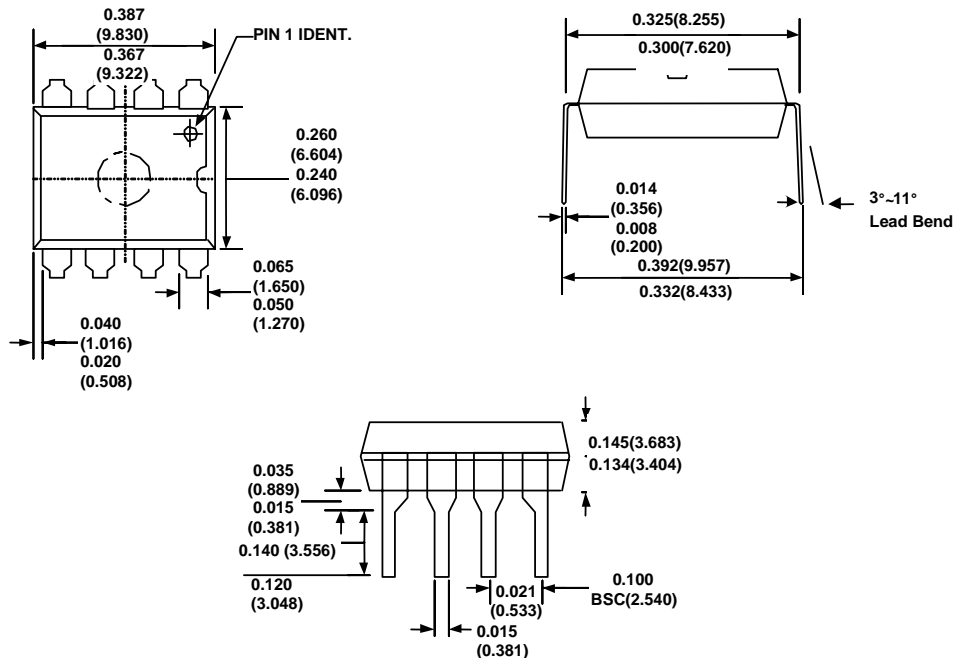

**Figure 2—External Bootstrap Diode**

This diode is also recommended for high duty cycle operation (when  $\frac{V_{OUT}}{V_{IN}} > 65\%$ ) and high output voltage ( $V_{OUT} > 12V$ ) applications.


**Figure 3—Application Circuit for -5V Supply**

**PACKAGE INFORMATION**
**SOIC8**


**NOTE:**  
1) Control dimension is in inches. Dimension in bracket is millimeters.

**PDIP8**


**NOTE:**  
1) Control dimension is in inches. Dimension in bracket is millimeters.

**NOTICE:** The information in this document is subject to change without notice. Please contact MPS for current specifications. Users should warrant and guarantee that third party Intellectual Property rights are not infringed upon when integrating MPS products into any application. MPS will not assume any legal responsibility for any said applications.