

ft1960F is a MP3 and MIDI interface based hi-grade audio synthesis processor mixed signal VLSI, developed specifically for MP3 playback, music ringers and game sounds. With a built in mixer, equalizer, speaker and headphone amplifiers, this

VLSI is an ideal device for cellular phones, PDAs and other mobile devices.

With high quality on-chip wavetables compatible with General MIDI sound set and high performance DSP, ft1960F are

capable of playing 16 timbres and 64 polyphonies MIDI sound simultaneously or MP3 sound.

This audio synthesis processor is able to present sounds by MIDI messages, arbitrary ADPCM voices and MP3 stream. There are three on-chip FIFOs used to store musical score data, MIDI messages, ADPCM audio data and MP3 audio data.

ft1960F is designed to provide maximum performance with minimum power consumption.

ft1960F has a built-in hardware sound synthesizer that is capable of complex sound replay with minimal loading by the host CPU. This VLSI also has built-in LED controller, Vibrator controller and internal PLL loop filter. A fantastic music ringer subsystem can readily be built around this chip with minimum external components and cost.

The device is available in a thin plastic 48pin LPCC (QFN) package. The pinout is organized to provide optimal PCB layout suitable for cellular phone and PDA applications.

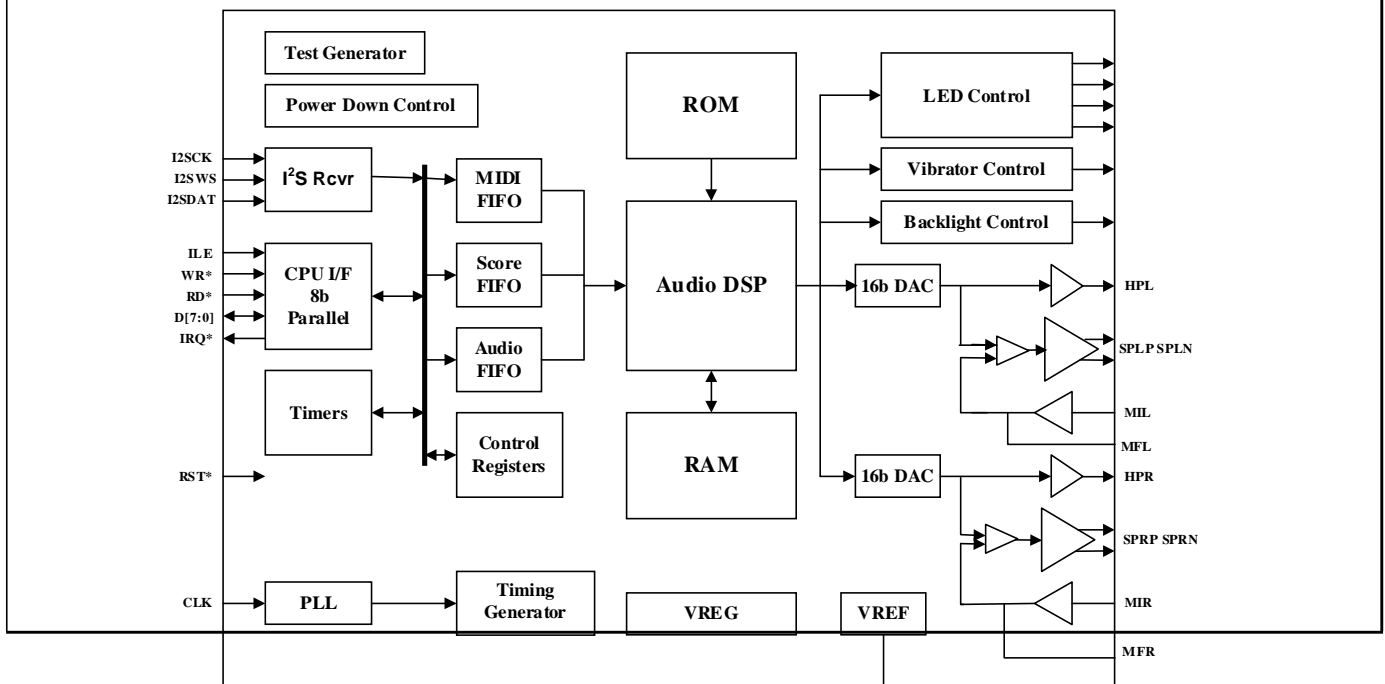

Features

- MP3 decoder
- On-chip high-quality wavetable sound set
- Simultaneous generation of 16 timbres, 64 polyphonies
- Compatible with General MIDI (GM) system level 1
- 128 timbres + 47 percussions embedded
- Stream replay with ADPCM
- 8-bit parallel I/F for CPU controlling
- 3 embedded FIFOs to reduce the host CPU loading
- Complies with the low voltage CPU interface (1.8V typical)
- Contains 16-bit stereo D/A converter
- SRS **WOW XT™**, surround sound technology
- Internal stereo headphone amplifier and speaker amplifier
- Built-in PLL with internal loop filter, and inputting of master clock up to 34MHz
- Vibrator motor and LED control
- Power down mode with power down current less than 0.3µA (typ.)
- Operating current: 30mA (typ.)
- Digital power supply (VDD: for internal core) 2.7 ~ 3.3V
- Digital I/O power supply (VDDIO: for CPU I/O) 1.65 ~ VDD
- Analog power supply (VDDA: for analog blocks) 3.0~ 4.5V

- 48pin LPCC (QFN) plastic package

1960F-8445687202

Pin Diagram

48 pin LPCC (QFN)

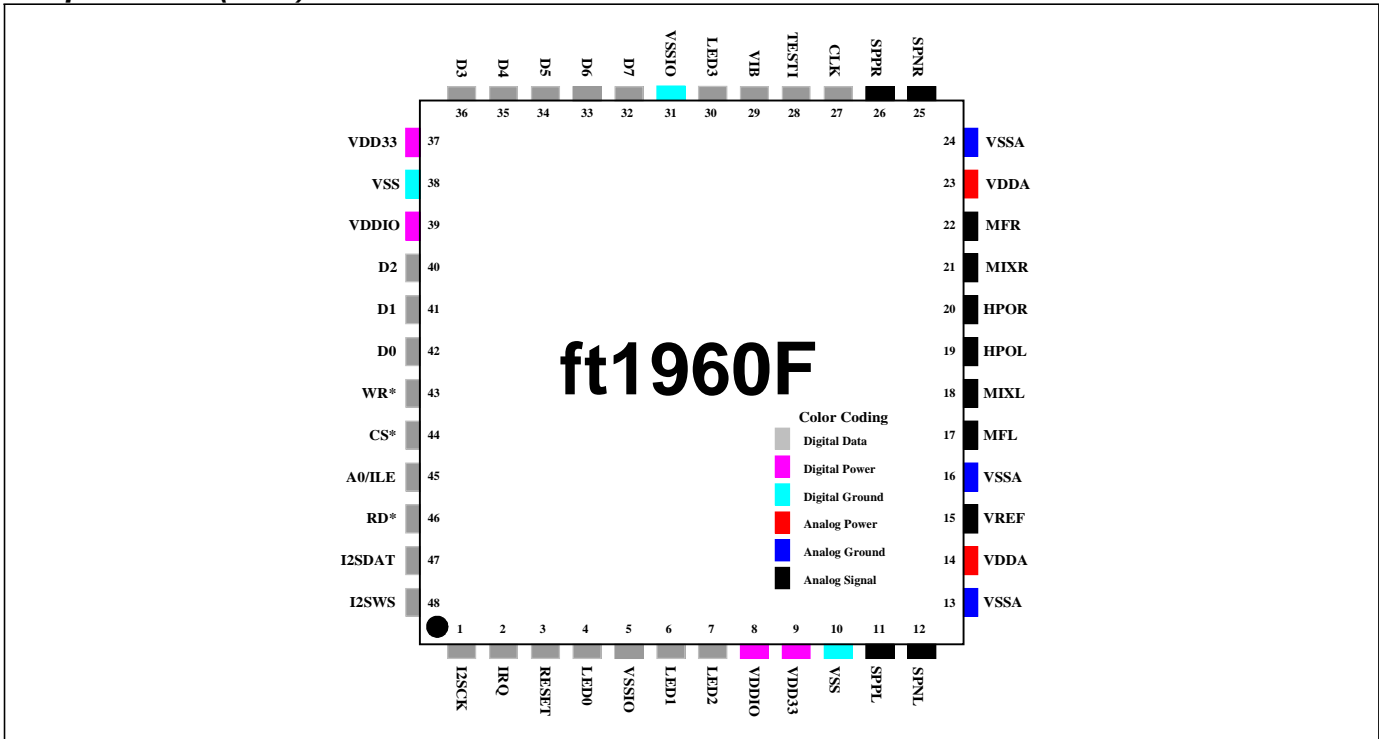

Software Support

The following software is available (subject to a non disclosure agreement):
 Support software for standard MIDI, Real Time MIDI, ADPCM, etc.

Applications

- Cellular phones
- PHS phones
- PDAs

IMPORTANT NOTICE

1. Disclaimer: The information in document is intended to help you evaluate this product. Fangtek, Inc. makes no warranty, either expressed or implied, as to the product information herein listed, and reserves the right to change or discontinue work on this product without notice.
 2. LIFE SUPPORT POLICY: FANGTEK'S PRODUCTS ARE NOT AUTHORIZED FOR USE AS CRITICAL COMPONENTS IN LIFE SUPPORT DEVICES OR SYSTEMS WITHOUT THE EXPRESS WRITTEN APPROVAL OF THE PRESIDENT AND GENERAL COUNSEL OF FANGTEK INC. As used herein Life support devices or systems are devices or systems which, (a) are intended for surgical implant into the body, or (b) support or sustain life, and whose failure to perform when properly used in accordance with instructions for use provided in the labeling, can be reasonably expected to result in a significant injury to the user.
 A critical component is any component of a life support device or system whose failure to perform can be reasonably expected to cause the failure of the life support device or system, or to affect its safety or effectiveness.
 3. FANGTEK ASSUMES NO LIABILITY FOR INCIDENTAL, CONSEQUENTIAL OR SPECIAL DAMAGES OR INJURY THAT MAY RESULT FROM MISAPPLICATIONS OR IMPROPER USE OR OPERATION OF ITS PRODUCTS.
 4. FANGTEK MAKES NO WARRANTY OR REPRESENTATION THAT ITS PRODUCTS ARE SUBJECT TO INTELLECTUAL PROPERTY LICENSE FROM FANGTEK OR ANY THIRD PARTY, AND FANGTEK MAKES NO WARRANTY OR REPRESENTATION OF NON-INFRINGEMENT WITH RESPECT TO ITS PRODUCTS. FANGTEK SPECIFICALLY EXCLUDES ANY LIABILITY TO THE CUSTOMER OR ANY THIRD PARTY ARISING FROM OR RELATED TO THE PRODUCTS' INFRINGEMENT OF ANY THIRD PARTY'S INTELLECTUAL PROPERTY RIGHTS, INCLUDING PATENTS, COPYRIGHT, TRADEMARK OR TRADE SECRET RIGHTS OF ANY THIRD PARTY.
 5. THE INFORMATION IN THIS DOCUMENT IS MERELY TO INDICATE THE CHARACTERISTICS AND PERFORMANCE OF FANGTEK PRODUCTS. FANGTEK ASSUMES NO RESPONSIBILITY FOR ANY INTELLECTUAL PROPERTY CLAIMS OR OTHER PROBLEMS THAT MAY RESULT FROM APPLICATIONS BASED ON THE DOCUMENT PRESENTED HEREIN. FANGTEK MAKES NO WARRANTY WITH RESPECT TO ITS PRODUCTS, EXPRESS OR IMPLIED, INCLUDING, BUT NOT LIMITED TO THE WARRANTIES OF MERCHANTABILITY, FITNESS FOR A PARTICULAR USE AND TITLE.
 6. Trademarks: The company and product names in this document may be the trademarks or registered trademarks of their respective manufacturers. Fangtek is trademark of Fangtek, Inc.