

# ft2012

## 2.7W/ch Stereo Filter-free Class-D Audio Power Amplifier

### General Description

The ft2012 is a 2.7W/ch stereo high efficiency filter-free class-D audio power amplifier. The ft2012 can operate from 2.7 to 5.5V supply. When powered with 5V voltage, the ft2012 can deliver 2.7W per channel to dual 4 load at 10% THD+N, and also capable of driving 1.5W/ch to dual 8 load. The ft2012 is thermally limited in WCSP and may not achieve 2.7W/ch for 4 .

As a Class D audio power amplifier, the ft2012

supports 90% high efficiency and -75dB PSRR at

217Hz which make the device ideal for battery-supplied, high quality audio applications. The ft2010 features independent shutdown controls for each channel. The gain can be selected to 6, 12,

18, or 24 dB utilizing the G0 and G1 gain select pins. The ft2012 also features the minimized click-and-pop noise during the turn-on and shutdown.

The ft2012 is manufactured in space-saving QFN-20 (4mm x 4mm) and WCSP-16 (2mm x 2mm) package Applications

### Applications

- ③ Mobile phone
- ③ Personal Digital Assistant(PDA)
- ③ Portable gaming device
- ③ Powered speakers
- ③ Notebook computer

### Features

- ③ Output power
  - 2.7W/ch into 4 at 5V
  - 1.5W/ch into 8 at 5V
  - 750mW/ch into 8 at 3.6V
- ③ PSRR: -75dB (typical)
- ③ CMRR: -70dB (typical)
- ③ Efficiency up to 90%
- ③ Only two external components required
- ③ Independent shutdown control for each channel
- ③ Short-circuit and thermal protection
- ③ Shutdown current: 0.1μA (typical)
- ③ Power supply range: 2.7V to 5.5V)
- ③ Packaging
  - QFN-20 (4mm x 4mm)
  - WCSP-16 (2mm x 2mm)

### Pin Out Diagram

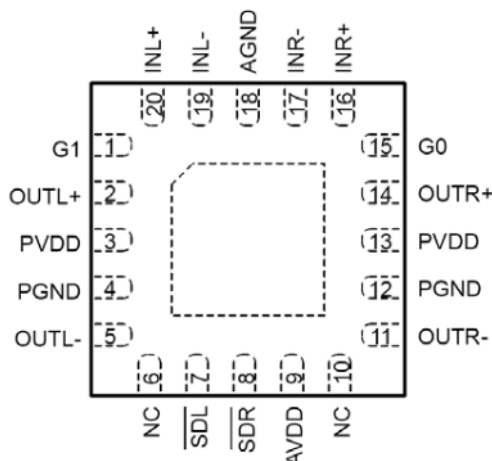

Figure1. QFN 20 Top View

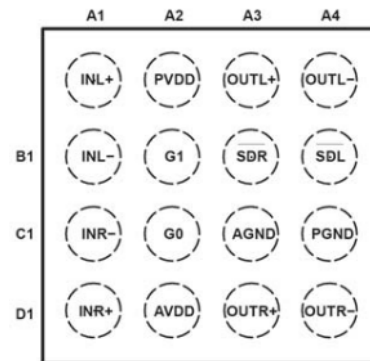

Figure2. WCSP 16 Top View

## Ordering Information

P/N	TEMP RANGE	PIN-PACKAGE
ft2012Q	-40°C to +85°C	20 pin QFN
ft2012W	-40°C to +85°C	16 ball WCSP

Note: The ft2012 is thermally limited in WCSP and may not achieve 2.7W/ch for 4 .

## Absolute Maximum Ratings

Supply Voltage ( $V_{DD}$ ) in active mode	-0.3 V to 5.5V
Supply Voltage ( $V_{DD}$ ) in shutdown mode	-0.3 V to 6.0V
Input Voltage ( $V_I$ )	-0.3V to $V_{DD}+0.3V$
Operating Free-air Temperature range ( $T_A$ )	-40°C to 85°C
Operating Junction Temperature range ( $T_J$ )	-40°C to +125°C
Storage Temperature ( $T_{STG}$ ) range	-65°C to +150°C

## Operation Ratings

Supply Voltage ( $V_{DD}$ )	2.7V to 5.5V
High Level Input Voltage ( $V_{IH}$ )	1.6V to $V_{DD}$
Low Level Input Voltage ( $V_{IL}$ )	0 to 0.35V
Operating Temperature ( $T_A$ )	-40°C to +85°C

## Electrical Characteristics

$T_A=25^\circ\text{C}$

Symbol	Parameter	Test Conditions	Min	Typ	Max	Unit
$ V_{OC} $	Output offset voltage (measured)	Inputs ac grounded, $A_v=6\text{dB}$ , $V_{DD}=2.7\text{V to }5.5\text{V}$		5	25	mV
PSRR	Power supply rejection ratio	$V_{DD}=2.7\text{V to }5.5\text{V}$		-75	-55	dB
CMRR	Common mode rejection ratio	Inputs shunted together, $V_{DD}=2.7\text{V to }5.5\text{V}$		-70	-50	dB
$ I_{IH} $	High-level input current	$V_{DD}=5.5\text{V}$ , $V_I=V_{DD}$			50	$\mu\text{A}$
$ I_{IL} $	Low-level input current	$V_{DD}=5.5\text{V}$ , $V_I=0\text{V}$			5	$\mu\text{A}$
$I_{DD}$	Supply current	$V_{DD}=5.5\text{V}$ , no load or output filter		7.5		mA
		$V_{DD}=3.6\text{V}$ , no load or output filter		5.5		
$I_{SD}$	Shutdown current			0.1		$\mu\text{A}$
$r_{DS(ON)}$	Static Drain-source On-state Resistance	$V_{DD}=5.5\text{V}$		420		m
		$V_{DD}=3.6\text{V}$		520		
	Output impedance in SHUTDOWN	$V_{(SHUTDOWN)}=0.35\text{V}$		2		k
$f_{(SW)}$	Switching frequency	$V_{DD}=2.7\text{V to }5.5\text{V}$		300		KHZ
	Closed-loop voltage gain	$G_0, G_1=0.35\text{V}$		6		dB
		$G_0=V_{DD}, G_1=0.35\text{V}$		12		
		$G_0=0.35\text{V}, G_1=V_{DD}$		18		
		$G_0, G_1=V_{DD}$		24		

## Operating Characteristics

$T_A=25^{\circ}\text{C}$ ,  $R_L=8$

Symbol	Parameter	Test Conditions	Min	Typ	Max	Unit
$P_O$	Output power (per channel)	THD+N=10%, $f=1\text{kHz}$ , $R_L=4$	$V_{DD}=5\text{V}$		2.7	W
		THD+N=10%, $f=1\text{kHz}$ , $R_L=8$	$V_{DD}=5\text{V}$		1.5	
			$V_{DD}=3.6\text{V}$		0.75	
THD+N	Total harmonic distortion plus noise	$V_{DD}=5\text{V}$ , $P_O=1\text{W}$ , $A_V=6\text{dB}$ , $f=1\text{kHz}$ , $R_C=8$		0.14%		
		$V_{DD}=5\text{V}$ , $P_O=0.5\text{W}$ , $A_V=6\text{dB}$ , $f=1\text{kHz}$ , $R_C=8$		0.10%		
	Channel crosstalk	$V_{DD}=3.6\text{V}$ , $f=1\text{KHz}$		-85		dB
$k_{SVR}$	Supply ripple rejection ratio	$V_{DD}=5\text{V}$ , $A_V=6\text{dB}$ , $f=217\text{Hz}$		-75		dB
		$V_{DD}=3.6\text{V}$ , $A_V=6\text{dB}$ , $f=217\text{Hz}$		-70		
$V_n$	Output voltage noise	$V_{DD}=3.6\text{V}$ , $f=20$ to $20\text{KHz}$ , Inputs ac-grounded,	No weighting	35		$\mu\text{V}$
			A weighting	27		
CMRR	Common mode rejection	$V_{DD}=3.6\text{V}$ , $V_{IC}=1V_{pp}$	$f=217\text{Hz}$	-70		dB
$Z_i$	Input impedance	$A_V=6\text{dB}$		28.1		k
		$A_V=12\text{dB}$		17.3		
		$A_V=18\text{dB}$		9.8		
		$A_V=24\text{dB}$		5.2		
	Start-up time from shutdown	$V_{DD}=3.6\text{V}$		3.5		ms

Note: The ft2012 is thermally limited in WCSP and may not achieve 2.7W/ch for 4 .

## Block Diagram

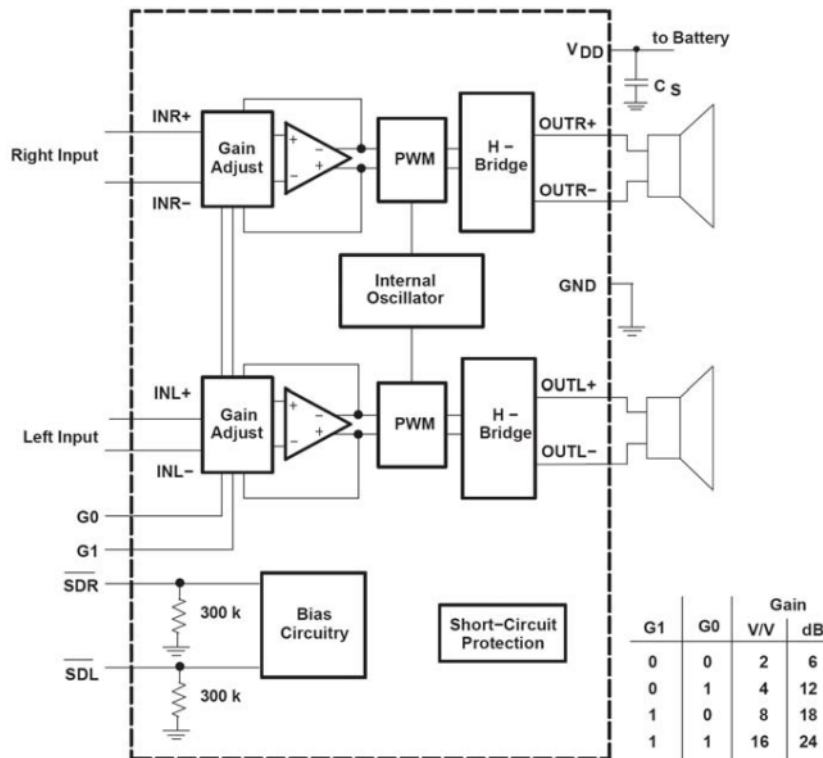

Figure3. Block Diagram

## Terminal Functions

Terminal			I/O	Description
Name	QFN	WCSP		
INR+	16	D1	I	Right channel positive input
INR-	17	C1	I	Right channel negative input
INL+	20	A1	I	Left channel positive input
INL-	19	B1	I	Left channel negative input
SDR	8	B3	I	Right channel shutdown terminal (active low)
SDL	7	B4	I	Left channel shutdown terminal (active low)
G0	15	C2	I	Gain select (LSB)
G1	1	B2	I	Gain select (MSB)
PV <sub>DD</sub>	3,13	A2	I	Power supply (Must be same voltage as AV <sub>DD</sub> )
AV <sub>DD</sub>	9	D2	I	Analog supply (Must be same voltage as PV <sub>DD</sub> )
PGND	4,12	C4	I	Power ground
AGND	18	C3	I	Power ground
OUTR+	14	D3	O	Right channel positive differential output
OUTR-	11	D4	O	Right channel negative differential output
OUTL+	2	A3	O	Left channel positive differential output
OUTL-	5	A4	O	Left channel negative differential output
NC	6,10	N/A		No internal connection
Thermal Pad				Connect the thermal pad of QFN or PWP package to PCB GND

## Application Information

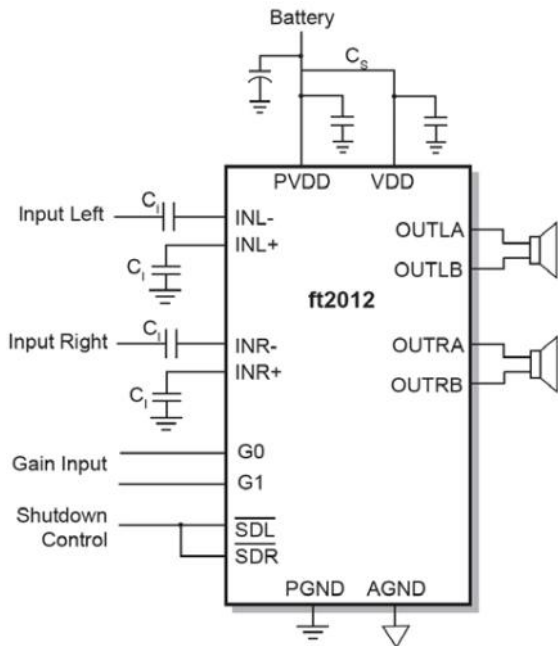

Figure4. Single-ended Input

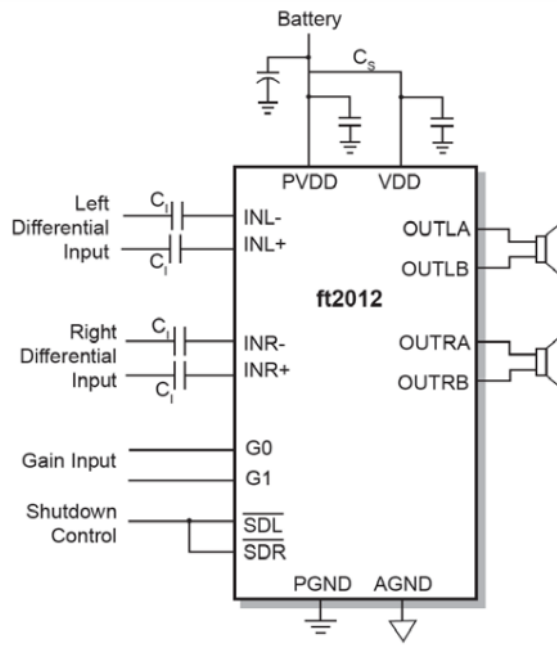

Figure5. Differential Input

## Decoupling Capacitor (C<sub>S</sub>)

The ft2012 is a high-performance Class-D audio amplifier that requires adequate power supply decoupling to ensure the efficiency is high and total harmonic distortion (THD) is low. For higher frequency transients, spikes, or digital hash on the line a good low equivalent-series-resistance (ESR) ceramic capacitor, typically 1 $\mu$ F, placed as close as possible to the device PV<sub>DD</sub> lead works best. Placing this decoupling capacitor close to the ft2012 is important for the efficiency of the Class-D amplifier, because any resistance or inductance in the trace between the device and the capacitor can cause a loss in efficiency. For filtering lower-frequency noise signals, a 4.7 $\mu$ F or greater capacitor placed near the audio power amplifier would also help, but it is not required in most applications because of the high PSRR of this device.

## Audio Amplifier Gain Setting

The ft2010 features four internally configured gain settings. The device gain is selected through the two gain select pins, G0 and G1. The gain settings are shown in the following table.

G1	G2	Gain (V/V)	Gain (dB)	R <sub>i</sub> (K )
0	0	2	6	28.1
0	1	4	12	17.3
1	0	8	18	9.8
1	1	16	24	5.2

Gain Setting Table

## Input Capacitors (C<sub>I</sub>)

The input capacitors and input resistors form a high-pass filter with the corner frequency, f<sub>c</sub>, determined in Equation 1.

$$f_c = \frac{1}{2\pi R_i C_i} \quad (1)$$

The value of the input capacitor is important to consider as it directly affects the bass (low frequency) performance of the circuit. Speakers in wireless phones cannot usually respond well to low frequencies, so the corner frequency can be set to block low frequencies in this application. Not using input capacitors can increase output offset.

If the corner frequency is within the audio band, the capacitors should have a tolerance of  $\pm 10\%$  or better, because any mismatch in capacitance causes an impedance mismatch at the corner frequency and below.

## Operation with DACs and CODECs

In using Class-D amplifiers with CODECs and DACs, sometimes there is an increase in the output noise floor from the audio amplifier. This occurs when mixing of the output frequencies of the CODEC/DAC mix with the switching frequencies of the audio amplifier input stage. The noise increase can be solved by placing a low-pass filter between the CODEC/DAC and audio amplifier. This filters off the high frequencies that cause the problem and allow proper performance.

## Filter Free Operation and Ferrite Bead

### Filters

A ferrite bead filter can often be used if the design is failing radiated emissions without an LC filter and the frequency sensitive circuit is greater than 1MHz. This filter functions well for circuits that just have to pass FCC and CE because FCC and CE only test radiated emissions greater than 30MHz. When choosing a ferrite bead, choose one with high impedance at high frequencies, and very low impedance at low frequencies. In addition, select a ferrite bead with adequate current rating to prevent distortion of the output signal.

Use an LC output filter if there are low frequency (<1MHz) EMI sensitive circuits and/or there are long leads from amplifier to speaker.

Figure 6 shows typical ferrite bead and LC output filters.

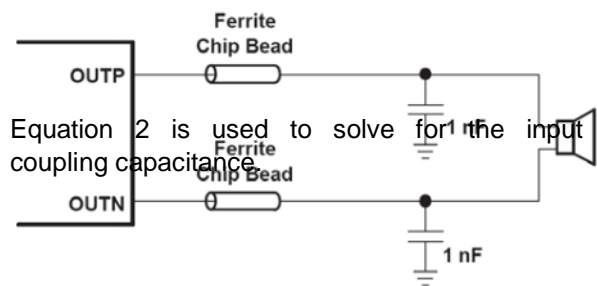

Figure6. Typical ferrite chip bead filter

$$C_i = \frac{1}{(2\pi R f_c)} \quad (2)$$

---

Mechanical Data

WCSP-16

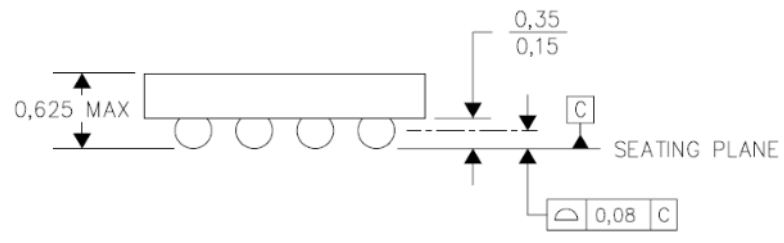
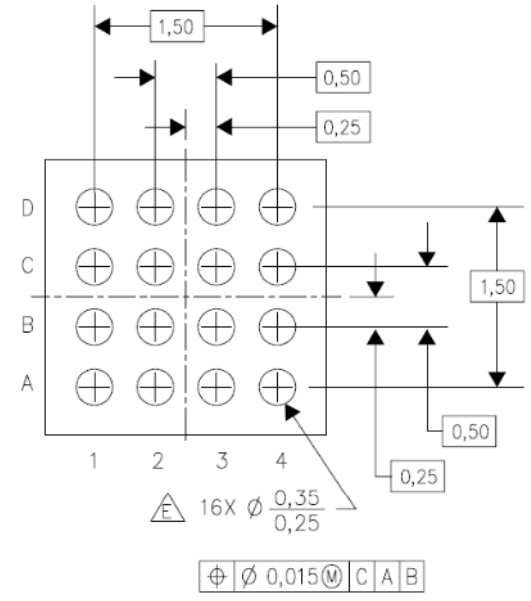
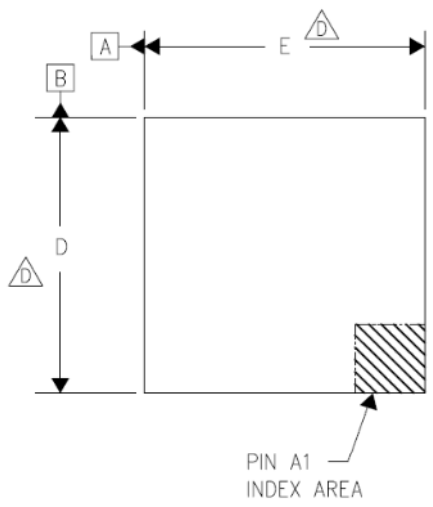

## QFN-20

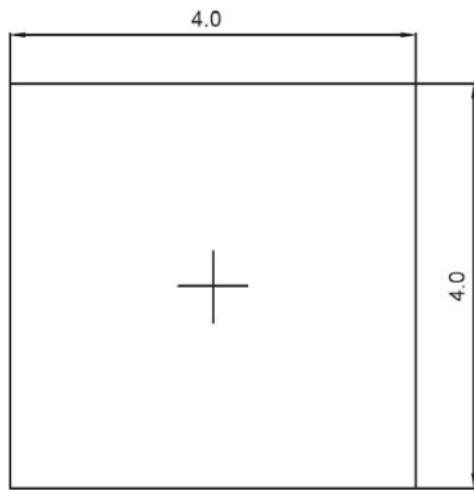

TOP VIEW

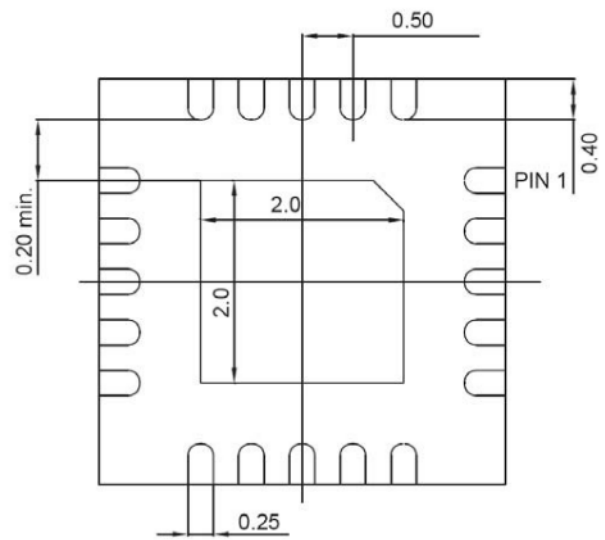

BOTTOM VIEW

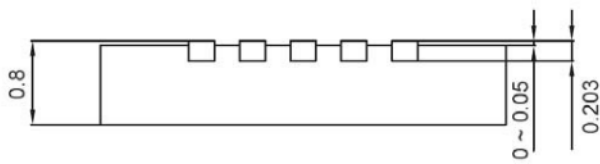

SIDE VIEW



IMPORTANT NOTICE

1. Disclaimer: The information in document is intended to help you evaluate this product. Fangtek, Inc. makes no warranty, either expressed or implied, as to the product information herein listed, and reserves the right to change or discontinue work on this product without notice.

2. LIFE SUPPORT POLICY: FANGTEK'S PRODUCTS ARE NOT AUTHORIZED FOR USE AS CRITICAL COMPONENTS IN LIFE SUPPORT DEVICES OR SYSTEMS WITHOUT THE EXPRESS WRITTEN APPROVAL OF THE PRESIDENT AND GENERAL COUNSEL OF FANGTEK INC. As used herein

Life support devices or systems are devices or systems which, (a) are intended for surgical implant into the body, or (b) support or sustain life, and whose failure to perform when properly used in accordance with instructions for use provided in the labeling, can be reasonably expected to result in a significant injury to the user.

A critical component is any component of a life support device or system whose failure to perform can be reasonably expected to cause the failure of the life support device or system, or to affect its safety or effectiveness.

3. FANGTEK ASSUMES NO LIABILITY FOR INCIDENTAL, CONSEQUENTIAL OR SPECIAL DAMAGES OR INJURY THAT MAY RESULT FROM MISAPPLICATIONS OR IMPROPER USE OR OPERATION OF ITS PRODUCTS

4. FANGTEK MAKES NO WARRANTY OR REPRESENTATION THAT ITS PRODUCTS ARE SUBJECT TO INTELLECTUAL PROPERTY LICENSE FROM FANGTEK OR ANY THIRD PARTY, AND FANGTEK MAKES NO WARRANTY OR REPRESENTATION OF NON-INFRINGEMENT WITH RESPECT TO ITS PRODUCTS. FANGTEK SPECIFICALLY EXCLUDES ANY LIABILITY TO THE CUSTOMER OR ANY THIRD PARTY ARISING FROM OR RELATED TO THE PRODUCTS' INFRINGEMENT OF ANY THIRD PARTY'S INTELLECTUAL PROPERTY RIGHTS, INCLUDING PATENTS, COPYRIGHT, TRADEMARK OR TRADE SECRET RIGHTS OF ANY THIRD PARTY.

5. THE INFORMATION IN THIS DOCUMENT IS MERELY TO INDICATE THE CHARACTERISTICS AND PERFORMANCE OF FANGTEK PRODUCTS. FANGTEK ASSUMES NO RESPONSIBILITY FOR ANY INTELLECTUAL PROPERTY CLAIMS OR OTHER PROBLEMS THAT MAY RESULT FROM APPLICATIONS BASED ON THE DOCUMENT PRESENTED HEREIN. FANGTEK MAKES NO WARRANTY WITH RESPECT TO ITS PRODUCTS, EXPRESS OR IMPLIED, INCLUDING, BUT NOT LIMITED TO THE WARRANTIES OF MERCHANTABILITY, FITNESS FOR A PARTICULAR USE AND TITLE.

6. Trademarks: The company and product names in this document may be the trademarks or registered trademarks of their respective manufacturers. Fangtek is trademark of Fangtek, Inc.